

Step 1: pls connect each wire to each battery.

Pic1: common port connecting diagram

Pic2: separate port connecting diagram

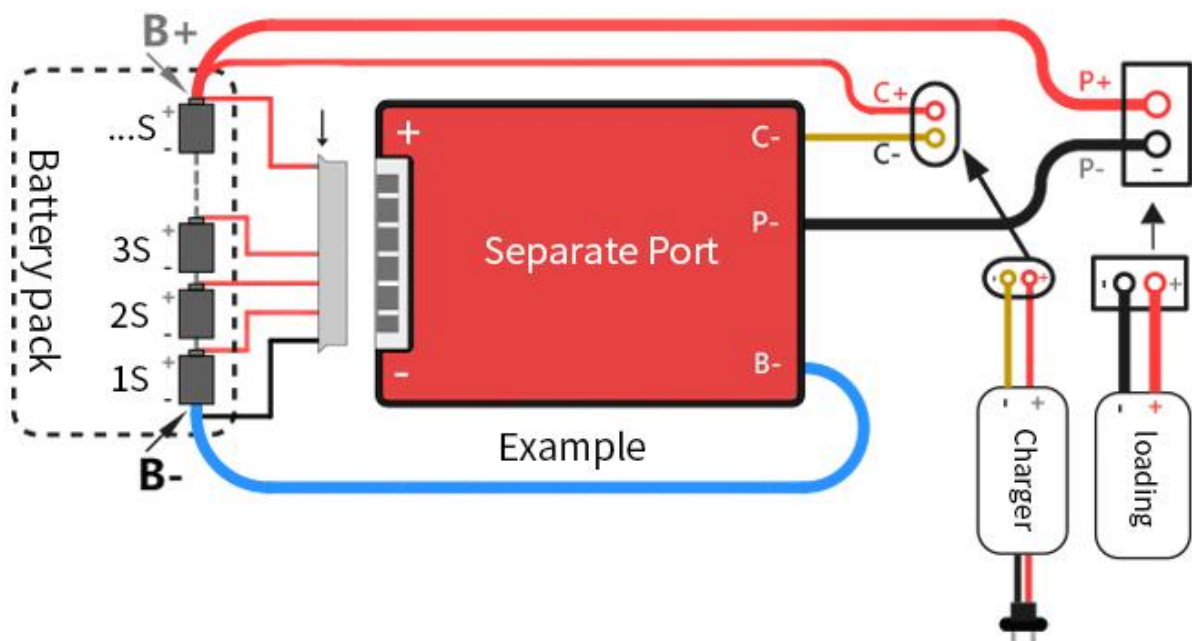
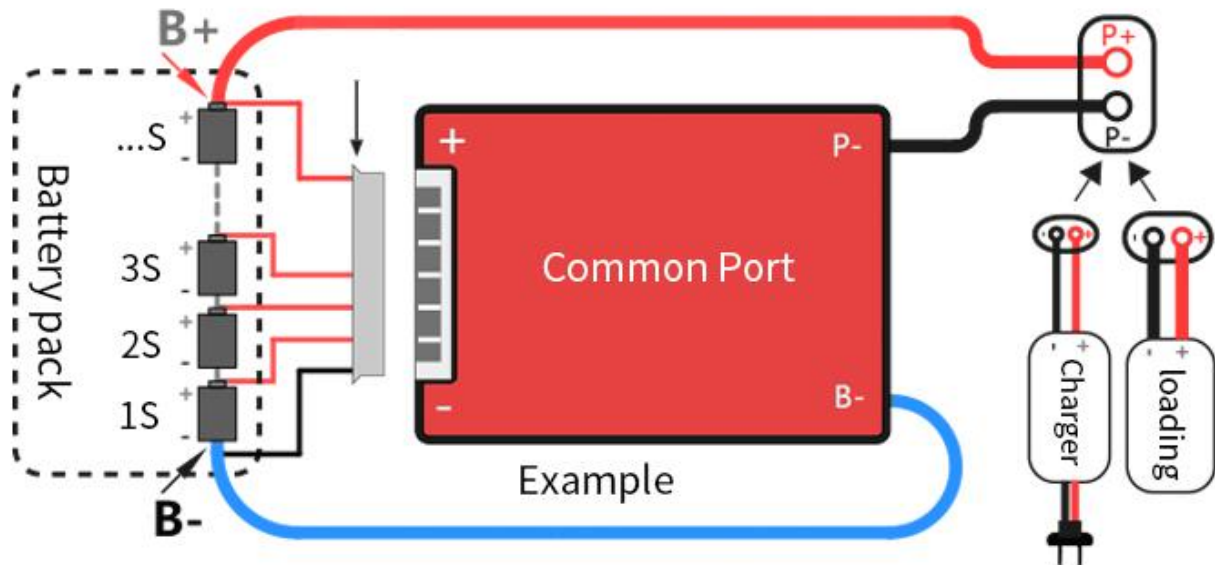

Step2: turn on your Multi-meter. and turn to V(DC)

before you connecting BMS you should use Multi-meter to test the voltage if are all the same.

Step 3: if above step have no problem, pls insert balance wires into BMS.

Step4: pls turn your Multi-meter to Ω , put Multi-meter probe on BMS's P- and B- if shows 0 Ω it means everything is ok.

Below is Multi-meter picture for you reference.

安全耐用 才是好工具

A GOOD TOOL IS ONE TIS SAFE

匠心精神 专注细节

